

 **STOREX**



**IND'FLY-520**



# TABLE OF CONTENTS

<b>SAFETY INFORMATION .....</b>	<b>3</b>
<b>GENERAL.....</b>	<b>4</b>
<b>SECURITY.....</b>	<b>4</b>
<b>POWER SUPPLY OF THE PRODUCT .....</b>	<b>4</b>
<b>SELECT THE LOCATION OF THE PRODUCT .....</b>	<b>4</b>
<b>CLEANING .....</b>	<b>4</b>
<b>TROUBLESHOOTING .....</b>	<b>5</b>
<b>SECURITY – ENVIRONMENT.....</b>	<b>5</b>
<b>LEGISLATION .....</b>	<b>5</b>
<b>PRESENTATION AND DETAILS OF THE PRODUCT .....</b>	<b>6</b>
<b>HOW TO USE IND'FLY.....</b>	<b>8</b>
<b>WARRANTY CONDITIONS .....</b>	<b>12</b>
<b>SITE WEB STOREX .....</b>	<b>13</b>
<b>WARRANTY REGISTRATION .....</b>	<b>13</b>



## SAFETY INFORMATION

This device has been designed and manufactured to ensure your safety. Security mechanisms built into the product will protect you if you observe the following installation procedures, use and troubleshooting:

Read carefully the instructions below and follow them before handling and installing your hardware.

Keep these instructions for future reference.

Please, read this warning before using **IND'FLY**. When using this product, you accept this warning and it means that you will read the whole document. **THIS PRODUCT IS NOT SUITABLE FOR PERSONS UNDER 18 YEARS OLD.** **IND'FLY** is a flying platform offering excellent flight experience, only if it is normally powered and in good condition. **IND'FLY** has an integrated autopilot system and grow our efforts to make the operation of the robot as safe as possible when the main power battery is connected, we strongly recommend you to remove all propellers during the calibration and the settings of the parameters. Make sure that all connections are good, and keep children and pets away during the upgrade of the firmware, system calibration and configuration parameters.

STOREX is not responsible for damage(s) or injury caused directly or indirectly from the use of this product in the following conditions:

- 1.** Damage(s) or accident caused by drunken person, medication, drugs, tiredness, nausea and other conditions, physically or mentally that could affect your physical and / or intellectual.
- 2.** Damage(s) or injuries caused by intentional subjective uses.
- 3.** Any repairs or damage caused by accident.
- 4.** Not following the instruction manual.
- 5.** Malfunctions caused by replacement of accessories and parts that do not come from the STOREX brand.
- 6.** Damage(s) or injury from the use of third party products or fake products not from STOREX.
- 7.** Damage(s) or injury from a bad use or bad judgment trajectory.
- 8.** Damage(s) or injuries caused by mechanical failures due to oxidation or aging of parts.
- 9.** Damage(s) or an injury caused by the use even after low voltage protection alarm is triggered.
- 10.** Damage (s) or injuries in the following situations: flight in magnetic interferences areas, radio interference, restricted areas by the government (no-fly zone), fly in backlight and bad view, it is not appropriate to use the drone in these conditions.
- 11.** Damage (s) or injury caused by the use during bad weather, such as rain, wind, snow, hail, lightning, tornadoes or hurricanes, etc.
- 12.** Damage (s) or injuries caused by the misuse of the battery.



## GENERAL

Do not shake the product as it may damage it.  
Use only parts and accessories (power supply ...) recommended by the manufacturer.  
The product images may vary from the actual product.

## SECURITY

To prevent fire or electric shock, do not place the unit near liquid-filled objects.  
If a heavy object or liquid is dropped on the device, have it checked by qualified personnel before using it again.  
During operation, the housing surface generates heat; therefore, do not cover or place any object on it.

## POWER SUPPLY OF THE PRODUCT

The included power adapter is specific to the product. The use of other adapters may damage the product or cause accidents.

## SELECT THE LOCATION OF THE PRODUCT

Install the unit away from any equipment with a strong attraction such as microwave ovens, big speakers ...

## CLEANING

Never open the product to clean as the warranty can be cancelled.  
Unplug the product from the wall outlet before cleaning the product.  
Clean the outside of the product using a soft dry cloth. Never use abrasive pad, scouring powder or solvent such as alcohol or gasoline.



## TROUBLESHOOTING

Refer all servicing to qualified personnel. Servicing is required when the device has been damaged in any way: damaged plug or power cord, liquid spilled on the product, putting small objects in the product, exposure to rain or moisture, malfunction, drop the product...

## SECURITY – ENVIRONMENT

Your STOREX product has been laboratory tested; it complies with European directives corresponding to the CE marking in effect at the time of its release.

Traceability of the components of your STOREX product was performed; It showed us that the product complies with the environmental directive (ROHS) in effect at the time of its release.

At the end of life of the product, do not throw it in the trash but file it in your household waste disposal which will pass the product to an electric, electromechanical and electronic waste recycling industry (WEEE).

## LEGISLATION

To comply with the current legislation, regarding the use of drones, please refer to the document below:

[http://www.developpement-durable.gouv.fr/IMG/pdf/Notice\\_drones\\_2015\\_VFF\\_web.pdf](http://www.developpement-durable.gouv.fr/IMG/pdf/Notice_drones_2015_VFF_web.pdf)



## PRESENTATION AND DETAILS OF THE PRODUCT

The **IND'FLY** is designed for flight enthusiasts. Before being shipped from the factory, it is configured and fully tested.



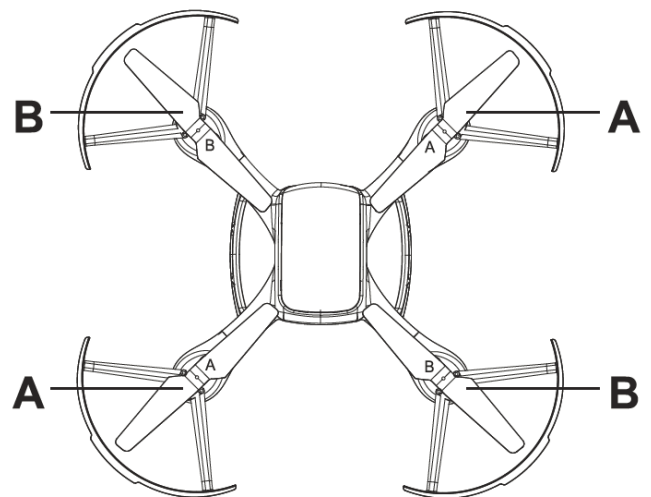

Your IND'FLY includes four installed propellers. When replacing your propellers, each kit of 4 is composed of 2 propellers which rotate clockwise and 2 propellers which rotate counterclockwise. When you replace a propeller, you must follow the diagram here: Propellers **A** on the arms of the drone marked with a letter **A** and propellers **B** on the arms of the drone marked with a letter **B**.

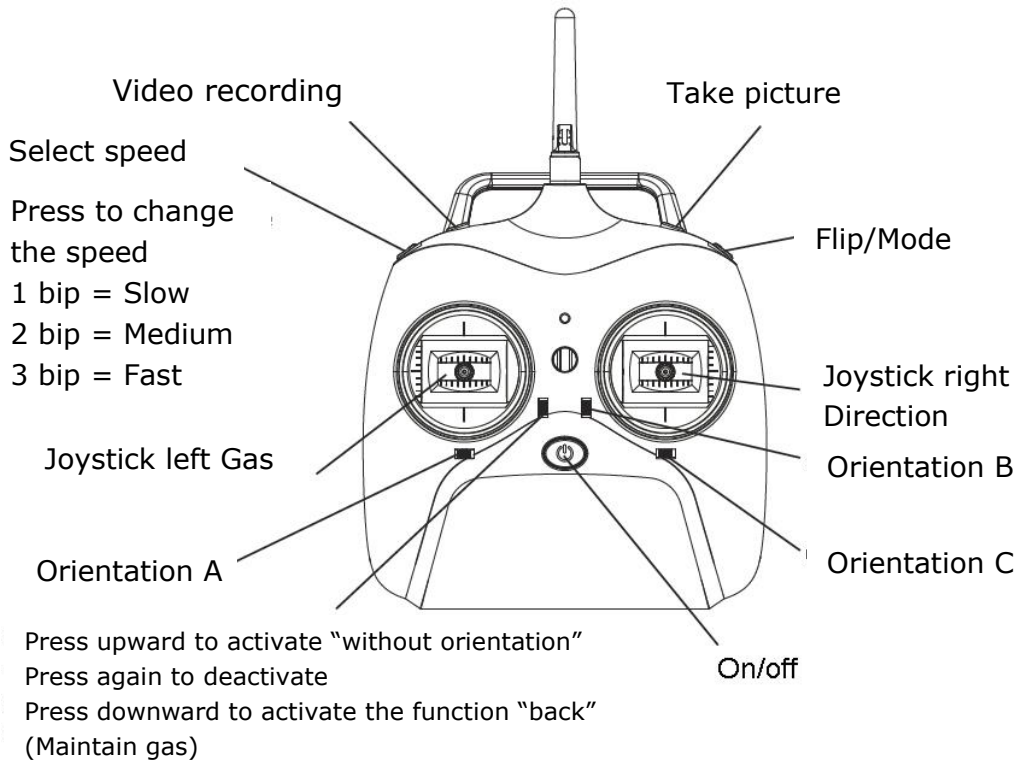



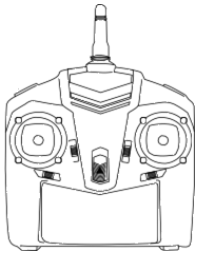

**NOTE:**The remote control may differ from actual model but the functions remain the same.

**CONTENT OF THE BOX**

Drone	Radio transmitter	Smartphone holder
		

**NECESSARY CONTENT (NOT INCLUDED)**

Cross-headed screwdriver	6 AA size batteries
	





# HOW TO USE IND'FLY

## BEFORE FLING

### Battery installation :

1. Open the battery compartment cover from the transmitter.
2. Install 6 AA batteries in accordance with the +/- poles.
3. Close the battery compartment cover from the transmitter.

### Turn on the remote :

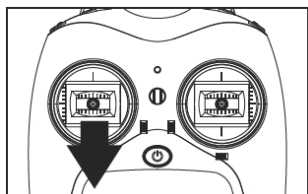

1. Move the left joystick all the way down.

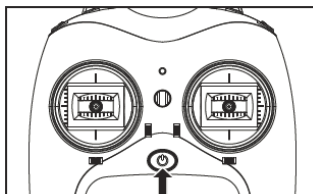

2. Turn on the radio control.

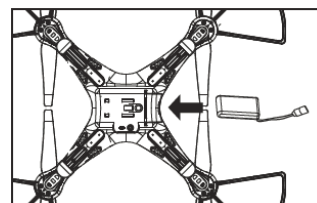

3. Open the battery compartment and insert the battery. Connect the battery to the drone.

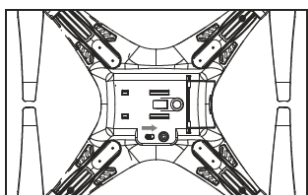

4. Turn on the drone DR- BEE(the LED under the drone arm flash fastly).

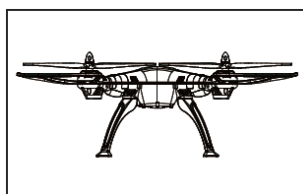

5. Place the drone DR- BEE horizontally, on a flat and clear area.

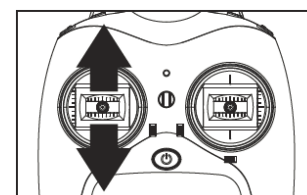

6. Push the joystick left at the top and at the bottom, you will hear a "beep" indicating that the R/C is connected to the drone (LEDs are fixed). The drone is ready to fly.

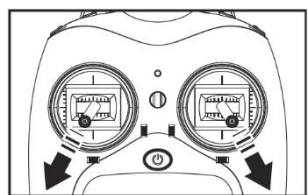

7. Push the two joysticks to the position as shown in the picture to unblock the drone.

### Control the drone :



### JOYSTICK LEFT

- Push upward to go up
- Push downward to go down

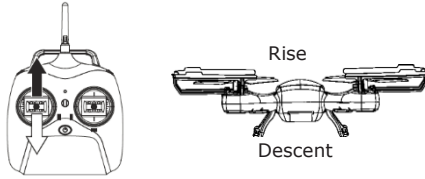

- Push to the left to rotate to the left
- Push to the right to rotate to the right

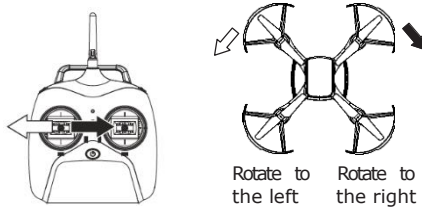

### JOYSTICK RIGHT

- Push upward to go forward
- Push downward to go backwards

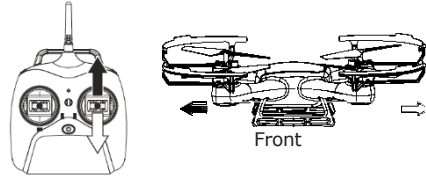

- Push to the left to fly to the left
- Push to the right to fly to the right

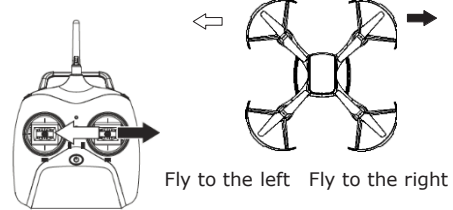

### Adjustment :

	<p>If the drone turns on itself, push <b>Direction B</b> to the left or right.</p>	
	<p>If the drone goes to the left or right, push <b>Direction C</b> to the left or right.</p>	
	<p>If the drone goes forward or backwards, push <b>Direction D</b> upwards or downwards.</p>	



## **Install the camera :**

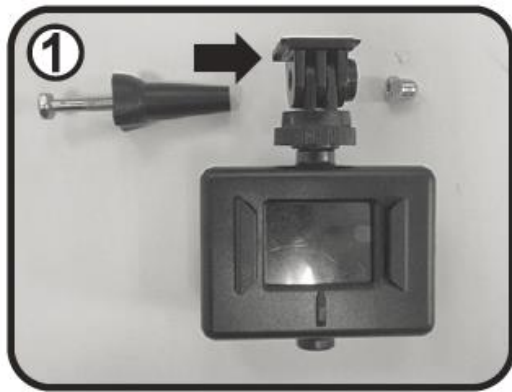

1. Assemble the camera in the mounting bracket.

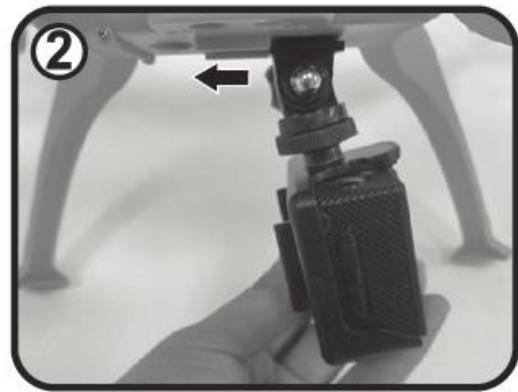

2. Fix the camera in the drone inserting the tabs into the notches.



3. Use the camera to take pictures or filming during the flight.

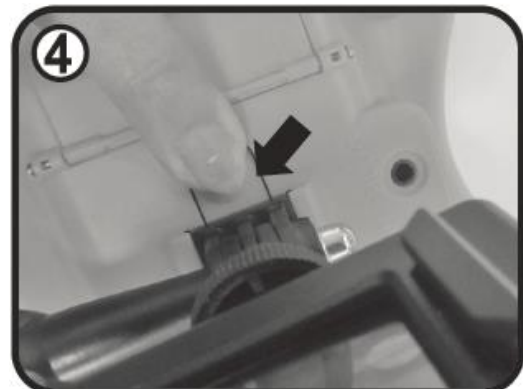

4. Push strongly in the notch to take away the camera from the drone.



## Install the smartphone holder :

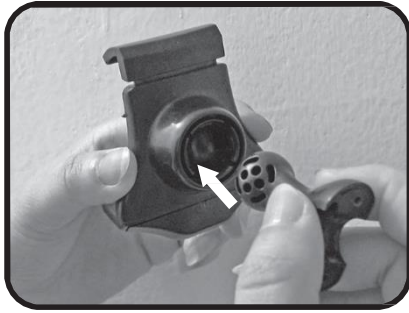

1. Insert the attachment inside the smartphone holder (push strongly).



2. Adjust the size of the support according to the size of your smartphone.



3. Install the bracket around the antenna of the radio.



4. Screw the bracket smartphone firmly around the antenna of the radio.

## **SPÉCIFICATIONS OF THE DRONE**

<b>Settings</b>	<b>Values</b>
Operating temperature	-10°C ~ 50°C
consumption autopilot	3.12W
Take-off weight	<1000g
Max. speed roll	200°/s
Max. tilt angle	45°
Up and down Max.	±6m/s
Max. speed flight	10m/s
Resolution camera	--
Weight	1000g
Weight of the battery	1200g



## WARRANTY CONDITIONS

The guarantee offered by **STOREX** is of 2 years for the product and 3 months for its accessories (cables, power supply ...).

**STOREX** guarantees your product against defects in manufacture or assembly. This warranty applies only to the end user and is not transferable if the unit is resold. The warranty does not cover inconsistencies detected by end users outside the recommendations of use printed on the package and generated incompatibilities with other hardware or software installed on the computer that is connected to the product.

The warranty does not cover failures or defects due to non-compliance with this manual instructions, negligence, product processing, improper installation or operation, repairs or changes not authorized by **STOREX**, inappropriate tests, accidents or external factors such as excessive heat or humidity, power failures or improper installation/ uninstallation of the product (not exhaustive list).

The only contractual obligation of **STOREX** involves the repair and replacement of a defective product. By no means, **STOREX** cannot be held responsible for loss of data or consequences following a malfunction or failure of the product. In any event, the **STOREX** financial responsibility cannot be held liable for an amount greater than the acquisition value of the product by the end customer.

This guarantee is well defined and cannot be changed, reduced or enlarged without written agreement from **STOREX**. In addition, **STOREX** cannot be held responsible for any technical advice or service provided in relation to the product.

For any request out of warranty, we invite you to contact **STOREX** support or log on to the website [www.e-storex.com](http://www.e-storex.com) for any accessories ordering.

You're not the assignee of this guarantee. The warranty covers your product and is governed by French law.

**Note:**

STOREX™ has the right to amend without notice the manual according to the changes of the product. Find the latest version of the manual on our website: <http://www.storex.eu>



## SITE WEB STOREX

Go to <http://www.storex.fr>.

## WARRANTY REGISTRATION

To facilitate your support during any interview with our support team, we invite you to register the warranty for your product on our website at:

<http://garantie.storex.eu>

In case of failure, please contact STOREX support to repair your product under warranty, or please send your request by e-mail at:

[support@storex.eu](mailto:support@storex.eu)

or by phone at

**France :**           **01 55 85 82 00** ([support.fr@storex.eu](mailto:support.fr@storex.eu))

**Portugal :**       **308 800 836**([apoio.pt@storex.eu](mailto:apoio.pt@storex.eu))

**Espagne :**       **902 110 572** ([soporte.es@storex.eu](mailto:soporte.es@storex.eu))

**Angleterre :**   ([support.uk@storex.eu](mailto:support.uk@storex.eu))

Monday to Thursday from 09.30am to 7.30pm.

Friday from 9.30am to 6.30pm.



 **STOREX**

**CE**